

PA820, PA778x Series

RG59 Splitter and Panels

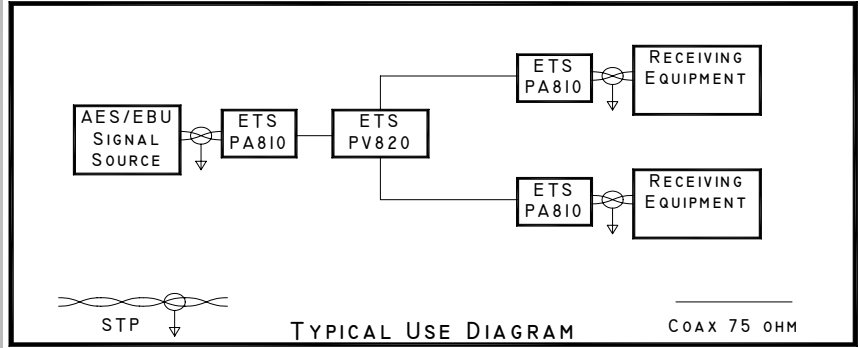

Features/Advantages	Description	Applications
<ul style="list-style-type: none"> Allows two outputs from a single source, without interference or impedance mismatching Individual splitters, or rack-mountable panel versions Panel mount models available from 2 to 12 channels Can be cascaded non-symmetrically for multiple outputs Metal cases, chassis Made in USA 100% tested 	<p>The ETS PA820 RG59 Splitter and the PA778x Series of AES/EBU Splitter Panels are carefully designed to divide the energy from a single source into equal parts, maintaining precise impedance matching. Return signals are routed back to the source with minimal crosstalk to the other port.</p> <p>These devices were expressly crafted for AES/EBU standard for digital audio. They minimize losses while preserving signal integrity. As an added benefit, our precision impedance matching technology allows for units to be non-symmetrically applied when being cascaded. Please note that each cascade stage reduces the signal level by 3 dB.</p>	<ul style="list-style-type: none"> Broadcast Control Rooms Recording Studios Post Production Facilities Satellite TV Facilities

Specifications		Product Ordering Information	
Bandwidth	10 kHz to 50 MHz	PA820	RG59 Splitter
Connectors	(3) BNC female 75Ω (per chan. on panels)		
Impedance	75Ω +/- 2% 50 kHz to 30 MHz		
Insertion Loss	0.25 dB 10 kHz to 50 MHz	PA778-4	RG59 Splitter Panel, 4 port
Note:	Splitting reduces signal level by 3 dB	PA778-8	RG59 Splitter Panel, 8 port
Crosstalk	35 dB down 50 kHz to 30 MHz	PA778-12	RG59 Splitter Panel, 12 port
		*** PA778-x Panels are considered custom products. Thus they are non-refundable, non-returnable.	
Dimensions	Panels: 1 RU x 80mm deep Baluns: 69mm x 69mm x 33mm		
Net Weight	Panels: 0.64 to 1.04 kg; Splitter: 0.1 kg		

© Copyright 2001-2009 Energy Transformation Systems, Inc.
 FatCat5 System panels and information outlets protected under US Patent Number 6,123,577. FatCat5, FatCat5 System, Chameleon Color Coding System, Balanced Star, Balanced Line, Monoline and Precision Wave are trademarks of Energy Transformation Systems. All other brand or product names are or may be trademarks of, and are used to identify, products or services of their respective owners. Revised 06/04/2001



Energy Transformation Systems, Inc.
 43353B Osgood Road, Fremont, CA 94539
 www.etslan.com
 800-752-8208 510-656-2012 Fax 510-656-2026

