

# PA882, PA883, PA886 Series

# SPDIF Digital Audio Baluns

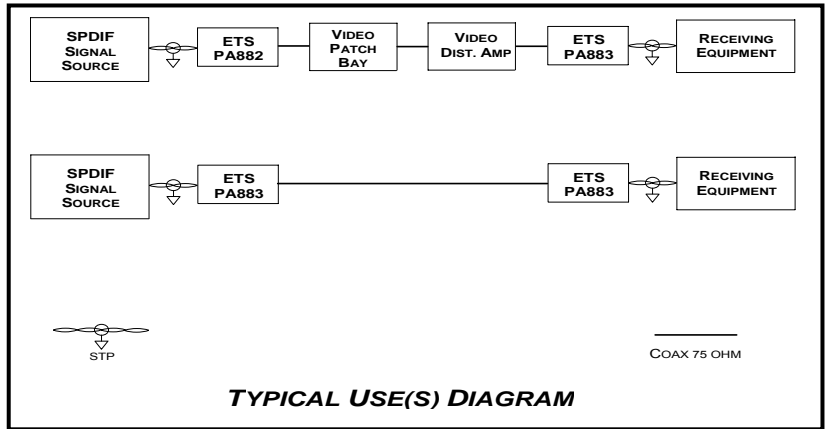

Features/Advantages	Description	Applications
<ul style="list-style-type: none"> <li>Converts SPDIF digital audio between balanced 110Ω XLR and unbalanced 75Ω BNC</li> <li>Metal cases</li> <li>Made in USA</li> <li>100% tested</li> </ul>	<p>ETS, long a leader in baluns for computer networks, applies our expertise in <b>Balanced Line™</b> technology to the <b>XLR to BNC Digital Audio Baluns (DAB)</b> and <b>DAB Panels</b>.</p> <p>The <b>PA882, PA883</b> and <b>PA886</b> baluns from ETS are designed to connect SPDIF signals from XLR output equipment into standard 75Ω coax cabling systems.</p> <p>These baluns perform precise impedance matching and signal balancing, allowing SPDIF signals to be transmitted with greater signal integrity and longer runs over coaxial cable than can be achieved with STP wiring.</p>	<ul style="list-style-type: none"> <li>Broadcast Control Rooms</li> <li>Recording Studios</li> <li>Post Production Facilities</li> <li>Satellite TV Facilities</li> </ul>

Specifications		Product Ordering Information	
Bandwidth	20 kHz to 60 MHz (1 dB)	PA882	SPDIF Balun, RCA jack to M-XLR w/20dB attenuation
Connectors	RCA jack to XLR	PA883	SPDIF Balun, RCA jack to F-XLR
Insertion Loss	< 0.15 dB	PA886	SPDIF Balun, RCA jack to M-XLR
Minimum Signal	0.5 V		
Impedance Match	75Ω to 110 Ω		
Common Mode Rejection	> 40 dB up to 40 MHz		
Distance	UTP – 330 ft, up to 2500 ft – 75 ohm coax		
Dimensions	20.3mm diameter x 89mm long		
Net Weight	0.03 kg		

© Copyright 1999-2009 Energy Transformation Systems  
 FatCat5 System panels and information outlets protected under US Patent Number 6,123,577. FatCat5, FatCat5 System, Chameleon Color Coding System, Balanced Star, Balanced Line, Monoline and Precision Wave are trademarks of Energy Transformation Systems. All other brand or product names are or may be trademarks of, and are used to identify, products or services of their respective owners. Revised 07/07/2009



**Energy Transformation Systems, Inc.**  
 43353B Osgood Road, Fremont, CA 94539  
 www.etslan.com  
 800-752-8208 510-656-2012 Fax 510-656-2026