

# PA900 Series

# Digital Audio (Time Code) Baluns

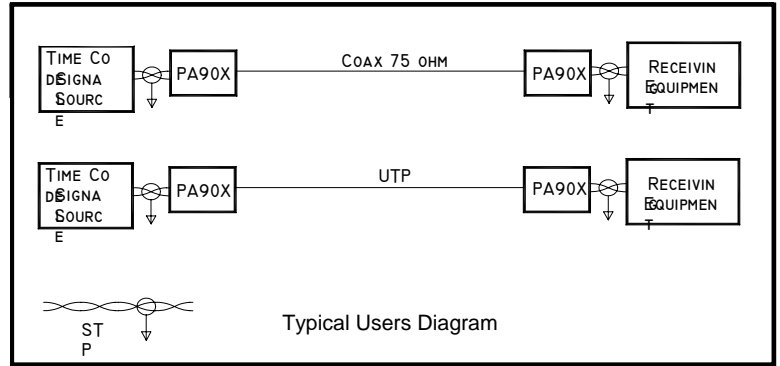

Features/Advantages	Description	Applications
<ul style="list-style-type: none"> <li>Converts Time Code digital audio between balanced 110Ω XLR to balanced 100Ω UTP or between balanced 110Ω balanced to unbalanced 75Ω BNC</li> <li>Rugged cases</li> <li>Made in USA</li> <li>100% tested</li> </ul>	<p>ETS, long a leader in baluns for computer networks, applies our expertise in <b>Balanced Line™</b> technology to the <b>XLR to UTP Digital Audio Baluns (DAB) and DAB Panels</b>.</p> <p>The <b>PA900</b> series of baluns from ETS are designed to connect Time Code signals from XLR output equipment into standard 75Ω coax or 100Ω UTP cabling systems. These baluns perform precise impedance matching and signal balancing, allowing Time Code signals to be transmitted with greater signal integrity and longer runs over coaxial or UTP cable than can be achieved with STP wiring.</p>	<ul style="list-style-type: none"> <li>Broadcast Control Rooms</li> <li>Recording Studios</li> <li>Post Production Facilities</li> <li>Satellite TV Facilities</li> </ul>

Specifications		Product Ordering Information	
Bandwidth	20 KHz to 60 MHz (1dB)	PA900	Time Code, 75Ω F-BNC to M-XLR
Connectors	XLR to RJ45 jack XLR to male or female BNC	PA901	Time Code, 75Ω F-BNC to F-XLR
Insertion Loss	< 0.15dB	PA902	Time Code, M-BNC to M-XLR
Impedance Match	110Ω to 100Ω (PA904 & PA905) 110Ω to 75Ω (PA900, PA901, PA902 & PA903)	PA903	Time Code, M-BNC to F-XLR
Comm Mode Reject.	> 40dB	PA904	Time Code, RJ45 jack pin 5,4 to 1.00 ft M-XLR
Distance	Up to 2500 ft with coax cable	PA905	Time Code, RJ45 jack pin 5,4 to 1.00 ft F-XLR
Distance	330 ft fir PA904 & PA905		
Dimensions	425mm x 25mm x 19mm (PA904 & PA905)		
	20.3mm dia. x 89mm long (PA900, PA901, PA902 & PA903)		
Net Weight	0.07 Kg (PA904 & PA905) 0.03 Kg (PA900, PA901, PA902 & PA903)		

© Copyright 2004 - 2009 Energy Transformation Systems, Inc.  
 FatCat5 System panels and information outlets protected under US Patent Number 6,123,577. FatCat5, FatCat5 System, Chameleon Color Coding System, Balanced Star, Balanced Line, Monoline and Procision Wave are trademarks of Energy Transformation Systems. All other brand or product names are or may be trademarks of, and are used to identify, products or services of their respective owners. Revised 07/06/09



**Energy Transformation Systems, Inc.**  
 43353B Osgood Road, Fremont, CA 94539  
 www.etslan.com  
 800-752-8208 510-656-2012 Fax 510-656-2026

